

## Staging and Sequencing Control for Compressors



More and more companies today need an economic operating air pressure system.

an internal timer is available e.g. shift work applications.

Thereby, several compressors are often connected to each other. Since 1995 Condor GLW controls have been used to monitor up to 4 compressors in primary load set up.

The GLW 4 evaluates the mains pressure and rotates the connected compressors on a time-dependent basis. If desired,

Following functions can be activated:

- Internal pressure transducer 0 to 16 bar
- Connection of an external pressure transducer, two-wire 4 to 20mA
- Programmable internal time switch (controls up to 6 profiles)
- Programmable primary load and load changeover functions, allowing for the primary load compressor to operate without taking part in the rotation process. Only the load changeover compressors are rotated.
- Programmable ball valve control with max. 3 compressors
- Direct switchover after the load changeover time has elapsed.
- Four digital inputs (e.g. for hourmeter )
- Input: bridge time switch
- Input: remote release
- Parameter password protection
- Units reversible bar/psi

## Type overview GLW 4



Order reference	Description	Weight (in g)	Part No.
GLW 4	GLW 4 without wiring, enclosure	520	237761
GLW 4-S	GLW 4 in pre-wired plastic enclosure, (dimensions: 420x300 x170mm), DIN-Rail mounting, internal terminal blocks and wiring diagram.	2350	255475
GLW 4-S kompl.	GLW 4 in pre-wired plastic enclosure, (dimensions: 420x300 x170mm), DIN-Rail mounting, internal terminal blocks and wiring diagram. Additionally wired for 4 compressors: isolator, rotary switch „bridge timer“, rotary switch compressor 1 - 4, indicator lamps for voltage supply and compressors 1 – 4.	3550	255482

Additional styles on demand!

# Electronic staging and sequencing control GLW 4

## Wiring diagram GLW 4-S (completely assembled)

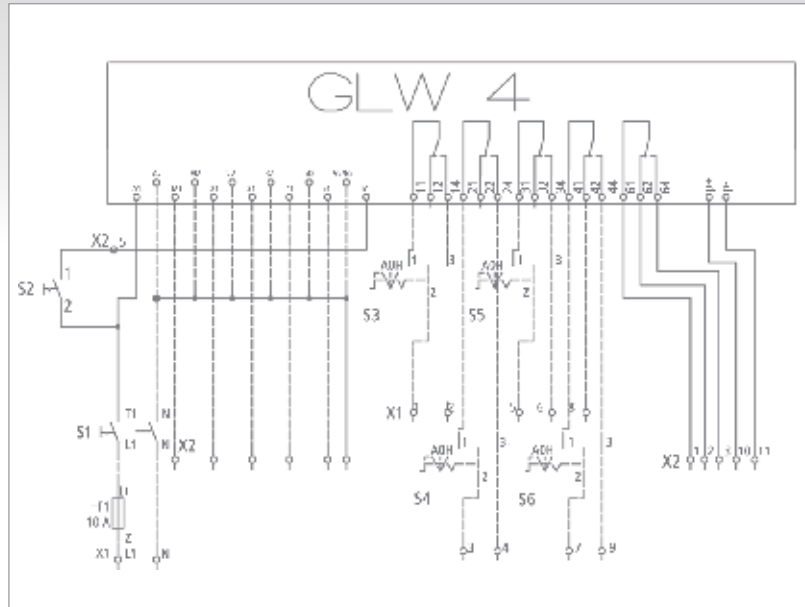
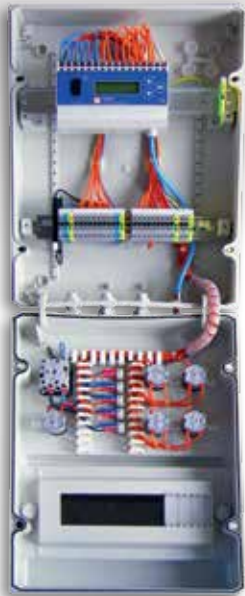

## Housing GLW 4 Terminal connections

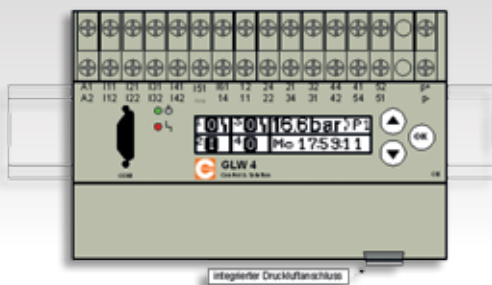

- A1 / A2 = Mains voltage supply 90 – 265 V AC; 50/60 Hz
- I 11 bis I 42 = 4 digital inputs, 250V AC1, e. g. operating hours
- I 51 = External release input, 250V AC1
- I 61 = Bridge time switch input, 250V AC 1
- 11 bis 44 = Isolated SPDT outputs for max. 4 compressors 230V AC, max. 5A AC1
- 51, 52, 54 = Isolated alarm relay 230V AC, max. 5A AC1
- p+ / p- = External analogue connection 4..20mA Two wire  
 $U_b = 18-21V$  DC
- COM = V 24-Interface for PC programming

Electronic Components

## Dimensions GLW 4 / GLW 4-S

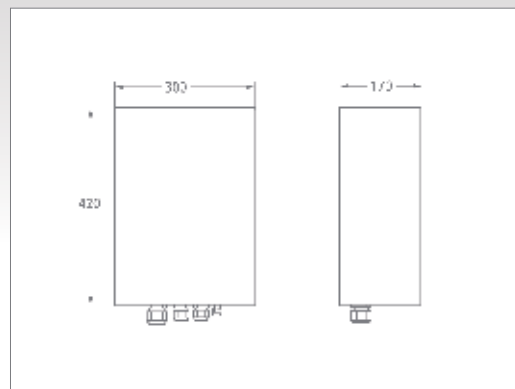
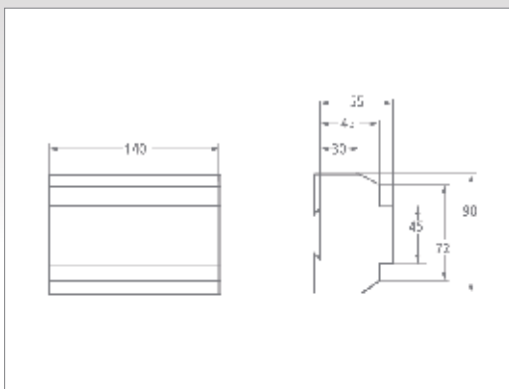

Technical operating data	
Permissible operating voltage range $U_B$	90 – 265 V AC 50 – 60 Hz
Operating voltage influence at $\pm 10\%$ operating voltage fluctuation	< 0,1 %
Duty factor ED	100 %
Permissible ambient and media temperature	0°C up to +40°C
Permissible ambient humidity rel. humidity, non-condensing	10 % up to 90 %
Permissible storage temperature	-40°C up to +80°C
Clearance and creepage distances	VDE 0110
Working position	Any position
Power consumption Control	10 VA

Power section	
Series voltage acc. to VDE 0660 and VDE 0110 Group C	250 V-AC
Maximum continuous current per contact	6 A-AC
Maximum switching capacity per contact	1.500 VA (AC) 50 W (DC)
Mechanical life Cycles	approx. $1 \times 10^7$
Electrical life (max load) Cycles	approx. $2 \times 10^5$

Measuring accuracy and Requirements	
Input external pressure transducer	$\pm 2\%$ of end value
Internal pressure transducer	$\pm 2\%$ of end value
EM-Directive	89 / 336 / EWG
Low Voltage Directive	73 / 23 / EW

Digital in- and outputs	
4 Relay outputs isolated SPDT's	230V-AC; 5 A (AC1)
1 Alarm relay isolated SPDT	230V-AC; 5 A (AC1)
Internal buzzer	typical 70dBA
4 digital inputs 250V	AC 1 (I11/I12 I41/I42)
Input 250V-AC1 (I51/52)	External release signal
Bridge time switch	250V-AC1 (I61/62)

Analogue Interface	
Input analogue pressure transducer $U_B$ 4...20mA wire	18 – 21V-DC
Integrated pressure transducer With quick connect	0...16 bar

Enclosure	
Material	ABS flameproof, UL-approved
Mounting	snap on 35 mm DIN-rail connector acc. to EN 50 035
Enclosure-protection	IP 40
Protection against shock	acc. VBG 4
Terminals	Cage clamps
Cross section	2,5 mm <sup>2</sup>
Weight	520 g

Pressure connection	
Pneumatic tube diameter suitable pneumatic tube e.g.	6 x 1 mm Festo PAN